



## DESCRIPTION

Improve security lighting around building perimeters by replacing existing metal halide fixtures with these more efficient LED wall packs.

## FEATURES

- Delivers up to 135 LPW
- Replaces 150W and 250W metal halide fixtures
- 0-10V dimming

## LISTINGS

- IP65 Rated
- UL Wet Location
- IK08
- DesignLights Consortium® 5.1 Premium - meets the requirements for the highest DLC qualification for efficacy and lumen maintenance

## PERFORMANCE

- CRI: 80
- CCT: 5000K
- LED L70 Life Hours: 100,000 hours

## ELECTRICAL

- THD: <20%
- Power Factor: >0.9
- Input Voltage: 120-277V
- Surge protection: 4kV

## THERMAL

- -40°F to 113°F (-40°C to 45°C) operating temperature

## CONSTRUCTION

- Heavy duty die-cast aluminum housing with bronze finish and anti-corrosion spray
- Durable borosilicate glass lens doesn't fade and allows high light transmittance

<b>Project name</b>	<b>Type</b>
<b>Catalog number</b>	
<b>Comments</b>	<b>Voltage</b>
<b>Approved by</b>	<b>Date</b>



## WARRANTY

- 5-year limited warranty; see [pltsolutions.com](http://pltsolutions.com) for warranty details

## APPLICATIONS

- General Security Lighting
- Pathways
- Loading Docks
- Building Perimeters

## PERFORMANCE SUMMARY

Item #	Watts	Lumens	LPW	CRI	CCT	Lens	Dimming	Voltage	Replaces	DLC #	DLC Level
PLT-13357	35W	4725	135	80	5000K	Glass	0-10V	120-277V	MH150	PLTBN 13X1	Premium 5.1
PLT-13358	50W	6750	135	80	5000K	Glass	0-10V	120-277V	MH250	PLTBN 23X1	Premium 5.1

## INSTALLATION HEIGHT REFERENCE



## DIMENSIONS

### **DIMENSIONS**

Height – 6.9"

Width – 9.1"

Width w/ hinges – 10.76"

Depth – 6.8"

Weight – 3.55 lbs

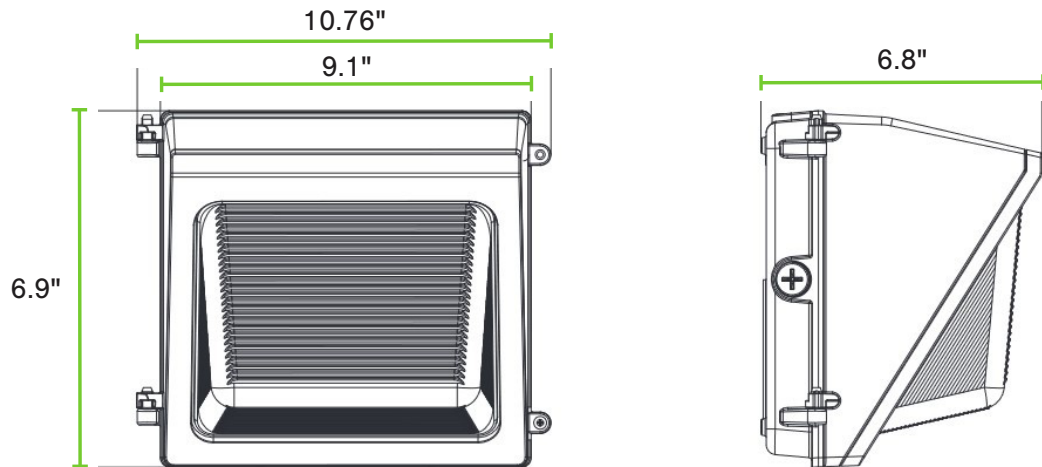

## PHOTOMETRICS

### **35W**

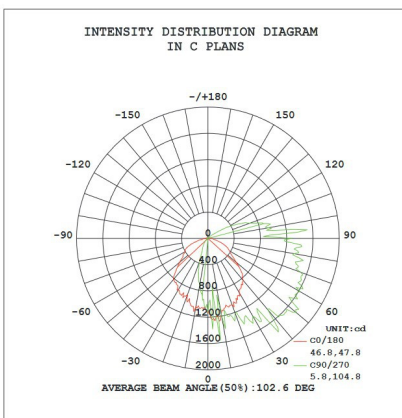

### **50W**

