

INSTRUCTIONS

WARNING! To reduce the risk of fire, electric shock, or injury to persons:

1. Turn off branch circuit breaker to all junction boxes before removing junction box cover, connecting fixtures to 110VAC wires, mounting fixture, replacing LED modules, or working on fixture in any manner.
2. Do not look directly into LEDs when lit.
3. Do not operate fixture(s) with missing or damaged parts.
4. Do not recess fixture in any material. Surface mount fixture using included cross bracket to 4" x 4" UL Listed metal junction box only. Do not mount fixture in unvented compartment.
5. Recommended maximum number of LED Sconce fixtures to be placed on a 15 amp circuit is 66 fixtures.
6. UL "Wet Location" Listed for wall mount applications only. Indoor/outdoor use has been tested and UL Listed in wall mount applications 9" above ground level grade, and no closer than 10 feet from swimming pools/Jacuzzis/shadow pools. See current NEC code and your local building department for all regulatory questions regarding your specific application.
7. Not for use with dimmers.
8. Properly dispose of all small parts and packing material. Small parts and packing material may be hazardous to children.
9. Install in accordance to manufacturer's instructions, current local codes, and/or the current National Electrical Code.

FIXTURE INSTALLATION GUIDE

1. Each LED Sconce Light ships with fixture, including attached junction box cover plate, and junction box cross bracket (see illustration).
2. Assure all power is off to 4" x 4" UL Listed junction box you wish to install LED Sconce Light.
3. Assure junction box is 9" or greater above ground/floor level, and no closer than 10' to a swimming pool, Jacuzzi, or shadow pool. Wall mount only.
4. Remove cover from wall junction box. Assure all wires have at least 1/2" of insulation stripped.
5. Note that one end of fixture has a larger lens than the opposite end. Our recommendation is to mount the fixture so that the smaller lens is "UP", and the larger lens points "DOWN".
6. Screw cross bracket onto junction box. Adjust fixture cross arm so that it is perpendicular to floor.
7. Note the white, black, and green wires interior to the junction box cover. Using UL Listed connectors (wire nuts), connect the white wire of the fixture to the white wire of wall junction box. Complete similar connections with black and green wires.
8. Fold all excess wire into wall junction box while mounting fixture onto bolts extending from junction box cross arm. Tighten fixture to wall with included cap nuts. See mounting illustration. If fixture does not fit snug to mounting surface, it is also possible to eliminate cap nuts, reverse bolts, and screw bolts through junction box cover into cross bracket.
9. In outdoor applications, apply a thin bead of clear silicon caulk around the edge of the fixture junction box cover and the wall.
10. After all fixtures have been completely installed, turn on branch circuit breaker. If any fixtures do not illuminate after 15 seconds, then turn off circuit breaker and check errant fixture for proper connections.

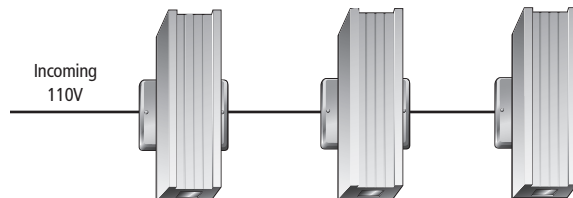

THROUGH-WIRE, 110V POWER

- Disconnect from all 110V power prior to installation.
- Connections must be made in accordance with all local electric codes and/or NEC.
- Interconnect up to 66 LED fixtures.
- 14 gauge (Romex Type) or better wire is required.
- Requires strain reliefs.
- Not for use with dimmers.

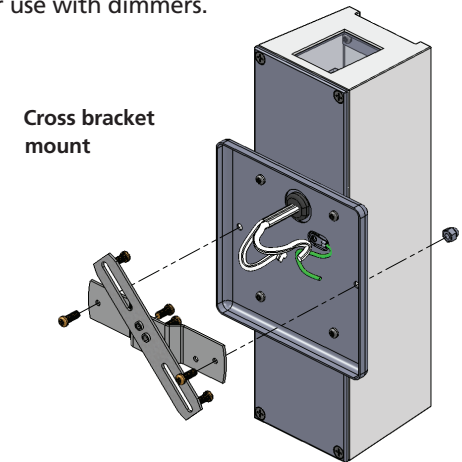

SPECIFICATIONS

- Fixture Energy Rating: Both modules: 110VAC, 70mA, 7.7 watts. One module: 110VAC, 40mA, 4.4 watts.
- Max. Fixtures per 110 VAC Tap: 66 Fixtures
- Average LED Life: 60,000 hours
- Replacement LED Module: NSL Part Number LEDMOD-12-CR
- Fixture Dimensions: 9 3/8" (H) x 2 3/4" (W) x 2 7/8" (D)
- Junction Box cover: 4 3/8" (H) x 4 3/8" (W) x 3/8" (D)
- Finish Options: Natural Aluminum, Bronze, Black, White
- UL Listing: UL Listed Wet Locations, for Indoor and Outdoor Applications

NATIONAL SPECIALTY LIGHTING
ARCHITECTURAL AND DECORATIVE LIGHTING

LOUISVILLE, CO 80027

www.nslusa.com

© 2011 National Specialty Lighting

5/11

RELAMPING LED MODULE

In the highly unlikely event of an LED module failure, please follow the instructions listed below:

CAUTION! If unit has recently been operating, glass, LED module(s), and fixture are hot! Turn off fixture and allow it to cool for 15 minutes before relamping.

CAUTION! Always replace LED module(s) with circuit breaker switch in the OFF position.

NOTE: Using a thin pair of gloves during this procedure will eliminate fingerprints on glass lens and LED module(s).

1. Turn OFF all power to fixture with LED module inoperative.
2. Remove fixture from 4" x 4" junction box by first:
 - A) Holding fixture with one hand.
 - B) Removing cap nuts from bolts extending through junction box cover (see previous illustration).
 - C) After cap nuts are removed, gently pull fixture from wall until you are able to access wire connections from fixture.
 - D) Remove wire connectors. Untwist all wires.
 - E) Remove fixture from wall and place on clean work surface with back of fixture facing up.
3. Remove fixture cover from fixture back plate by unscrewing six large screw bolts (see illustration).
4. Separate fixture cover from fixture back plate by gently placing a small screwdriver in mating gap and prying loose cover. Be very careful not to damage rubber gasket between fixture cover and fixture back plate.
5. Turn fixture over and notice two LED modules on either end of fixture. Push down on LED module male connector clip. This will disengage connector clip from female connector side inside fixture. With connector clip free, gently pull connector apart.
6. Unscrew old LED module. Replace with new LED module (NSL Part No. LEDMOD-12-CR). Tighten screws just snug.
7. Push male connector from LED module into female connector inside fixture. Make sure male connector clip engages to female connector.

8. Mate fixture cover to fixture back plate noting that gasket is in proper position and large screw bolt holes align properly. Replace and tighten six large screw bolts (see illustration).
9. Replace fixture by following the fixture Installation Guide included with these instructions.

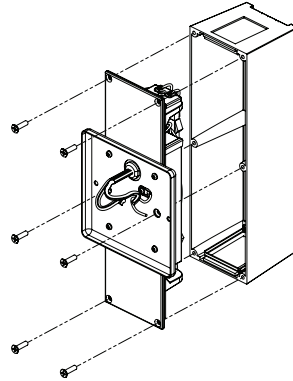

Fixture cover
off of back plate

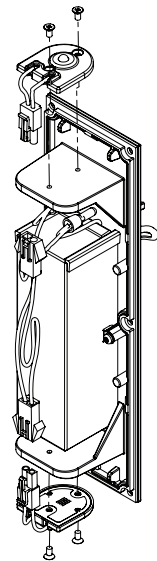

Modules off of
their mounting shelf

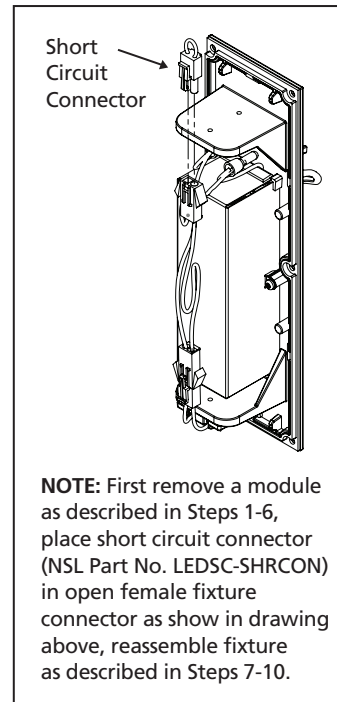

Single module option

INSTALLATION INSTRUCTIONS

LED SCONCE LIGHT

LED technology in an
indoor/outdoor listed
die cast aluminum fixture



60,000-hour LED life

•
Ultra low 7.7 watts per fixture

•
Mounts to UL Listed 4" x 4" Junction Box

•
White, Bronze, Black and Aluminum colors

•
Die cast aluminum construction

•
Top or bottom single light option

•
Replaceable LED modules

•
UL Listed wet location for interior
and exterior applications

NSL
NATIONAL SPECIALTY LIGHTING

UL US
LISTED
Wet Locations