

Features & Specifications

PLT & AREA LIGHTS

INTENDED USE – LED area lights are all-purpose site lighting fixtures that can be used for parking lots, car dealerships, outdoor stadiums, pathways, and parks. These LED fixtures will yield a significant reduction in energy consumption compared to standard HID systems and virtually eliminate ongoing maintenance expenses with a long-lasting lifespan. Designed for outdoor applications, the LED area light fixtures will provide reduced offsite visibility as well as effective security lighting.

CONSTRUCTION – Heavy-duty die cast aluminum housing with bronze polyester powder paint for corrosion-free durability. Resistant to rough vibrations and external impacts. Acrylic lens protects the LEDs and provides even light distribution. Housing is sealed with a silicone gasket, protecting against moisture and environmental contaminants (IP65 rated). Modular LED bricks wired in parallel for ease of maintenance.

OPTICS – High-performance LEDs maintain a 18,000 Lumen output at 5000K for 50,000 hours of use.

Type III light distribution is intended for perimeter lighting of parking lots and along the edges of an open area as well as large roadways and parking lot aisles. It casts more light forward so that it can be used to light roads and pathways from the side of the road rather than being installed in the median.

LED area lights are designed to have a more directional beam angle than metal halide and high pressure sodium fixtures so no light is lost within or above the fixture. These LED fixtures also do not lose Lumens in the same way as a HID fixture, meaning the brightness stays consistent longer and needs to be replaced far less frequently.

ELECTRICAL – Input voltage of 120-277 VAC, 50/60Hz. Consider adding a surge protector to protect your fixtures from power surges in your electrical system as an added insurance policy to your investment.

INSTALLATION – A straight-arm mounting bracket makes retrofit installation simple, resulting in reduced installation time and additional labor savings. Adjustable slipfitter is included for round pole mounting applications. Slipfitter mounts provide more flexibility and control over installation and light distribution by offering a broader range of angles than a stationary arm.

LISTINGS – ETL Certified to safety standards for wet location. Rated for -40°C to 45°C ambient temperature. DesignLights Consortium® (DLC) qualified product. IP-65 Rated.

WARRANTY – 5-year warranty. PLT products that are damaged or defective will be repaired or replaced at PLT's choosing for a period of 5 years. Contact 1-800-624-4488 for more information.

ADD-ONS – Pair with timers, photocells, and motion sensors for hassle free bright night time lighting and energy savings during the day. If pairing with a photocell, it must be LED compatible in order to operate properly. If using a conventional photocell, be sure to replace it with one rated for use with LEDs. While conventional light sensors will still work with LED fixtures at first, they will burn out prematurely. The same is true for motion sensors.

If you live in the northern hemisphere, your photocells should face north whenever possible. North-facing light sensors allow for the most balanced on/off schedule based on the arc of the sun. If pointed west, it will turn on and off late and vice versa for east-facing light sensors. Photocells facing the south will be exposed to the most direct sunlight which can burn out the components and cause premature failure. If you want your lights to come on early or late, we recommend pointing the light sensor northeast or northwest, respectfully. The opposite is true south of the equator.

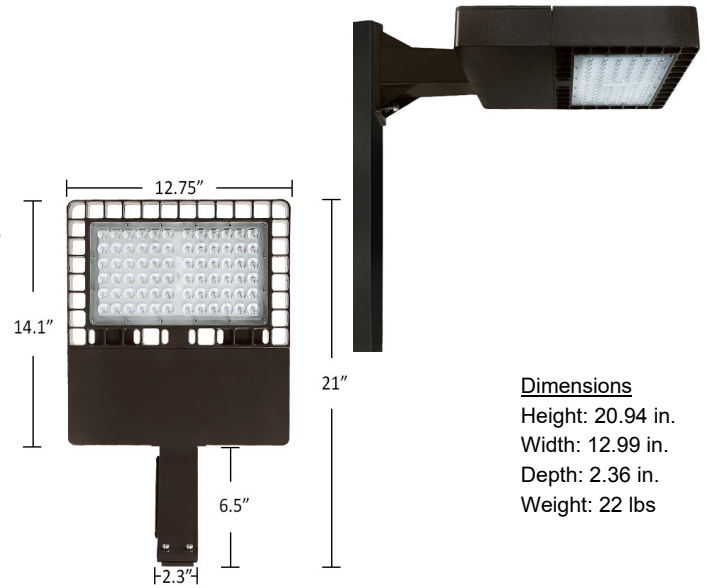

Dimensions
Height: 20.94 in.
Width: 12.99 in.
Depth: 2.36 in.
Weight: 22 lbs

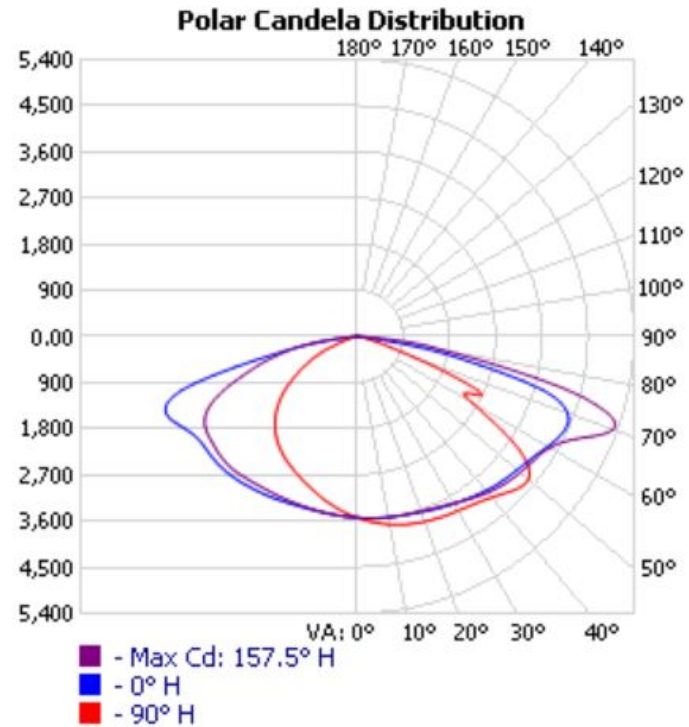

SKU #	Kelvin	Lumens	Wattage	Voltage	DLC?	Mounting	Life Hours	Warranty
KIT-10050	5000	18,000	150	120-277	YES	STRAIGHT ARM	50,000	5 YEAR

ZONAL LUMEN SUMMARY

ZONE	LUMENS	% LAMP	% LUMINAIRE
0-30	2,937.3	19.2%	19.2%
0-40	5,108.6	33.3%	33.4%
0-60	10,724.3	70%	70%
60-90	4,507.4	29.4%	29.4%
70-100	1,907.5	12.5%	12.5%
90-120	28.0	0.2%	0.2%
0-90	15,231.7	99.4%	99.5%
90-180	80.9	0.5%	0.5%
0-180	15,312.6	99.9%	100%

LUMENS PER ZONE

ZONE	LUMENS	% TOTAL	ZONE	LUMENS	% TOTAL
0-10	336.4	2.2%	90-100	5.8	0%
10-20	992.4	6.5%	100-110	9.7	0.1%
20-30	1,608.4	10.5%	110-120	12.6	0.1%
30-40	2,171.3	14.2%	120-130	13.6	0.1%
40-50	2,666.6	17.4%	130-140	12.8	0.1%
50-60	2,949.0	19.3%	140-150	10.9	0.1%
60-70	2,605.7	17.0%	150-160	8.4	0.1%
70-80	1,620.8	10.6%	160-170	5.3	0%
80-90	280.9	1.8%	170-180	1.8	0%

ROADWAY SUMMARY

CUTOFF CLASSIFICATION:	SEMICUTOFF	
DISTRIBUTION:	TYPE IV, SHORT	
MAX CD, 90 DEG VERT:	7.4	
MAX CD, 80 TO <90 DEG:	2,156.2	
	LUMENS	% LAMP
DOWNWARD STREET SIDE:	7,793.5	50.9%
DOWNWARD HOUSE SIDE:	7,439.0	48.6%
DOWNWARD TOTAL:	15,232.6	99.4%
UPWARD STREET SIDE:	39.8	0.3%
UPWARD HOUSE SIDE:	41.2	0.3%
UPWARD TOTAL:	80.9	0.5%
TOTAL LUMENS:	15,313.5	100%

LCS TABLE

BUG RATING	B3 - U3 - G3	
FORWARD LIGHT	LUMENS	LUMENS %
LOW(0-30):	1,483.9	9.7%
MEDIUM(30-60):	3,993.6	26.1%
HIGH(60-80):	2,168.3	14.2%
VERY HIGH(80-90):	147.7	1%
BACK LIGHT		
LOW(0-30):	1,453.3	9.5%
MEDIUM(30-60):	3,794.7	24.8%
HIGH(60-80):	2,057.9	13.4%
VERY HIGH(80-90):	133.2	0.9%
UPLIGHT		
LOW(90-100):	5.8	0%
HIGH(100-180):	75.1	0.5%
TRAPPED LIGHT:	7.5	0%

Isofootcandle Plot

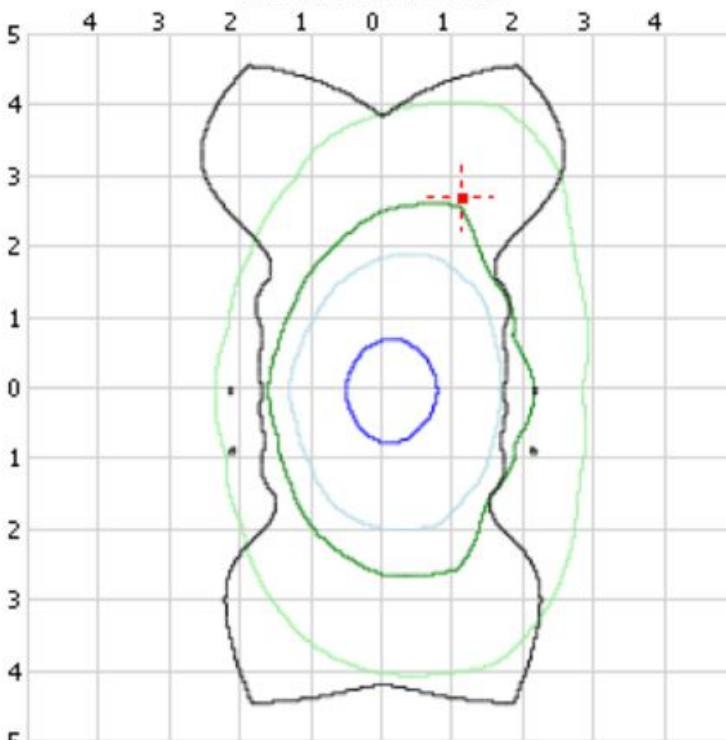

■ 20 fc ■ 1 fc
■ 10 fc ■ 0.5 fc
■ 5 fc ■ 0.1 fc ■ 50% Max Cd
 Distance in units of mount height (20ft) --- Max Cd

LCS Graph

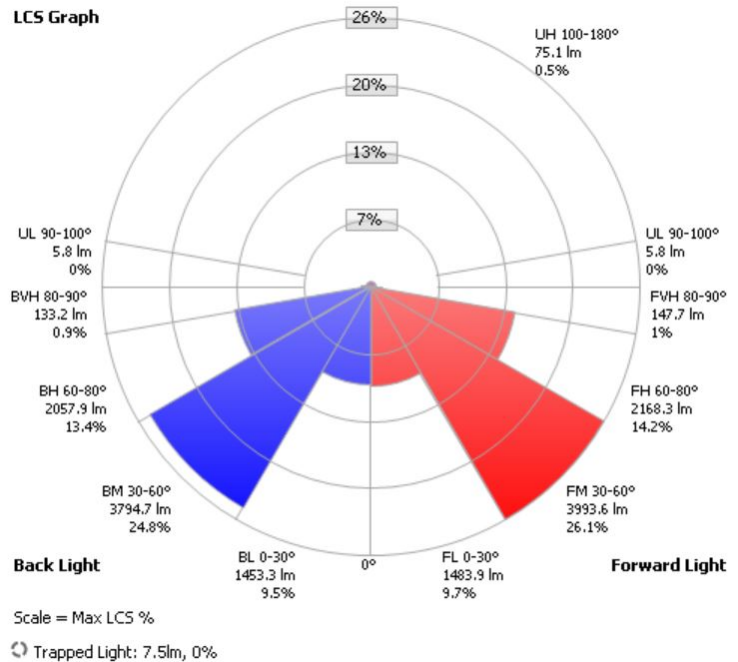

Back Light

Scale = Max LCS %

☉ Trapped Light: 7.5lm, 0%

