



WARNING

- Installation, service, and maintenance of luminaries should be performed by a qualified licensed electrician.

CAUTION

- Do not use an electric generator to test this fixture.
- If smoke or fire occurs during or after installation, turn off the power immediately and contact a licensed electrician.
- This fixture should be mounted a minimum of 2 meters above the ground.

NOTICE

- For outdoor use.

Installation Instructions

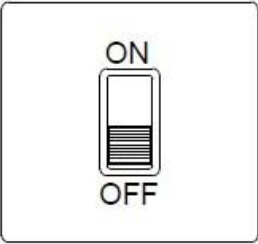
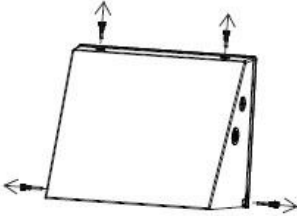
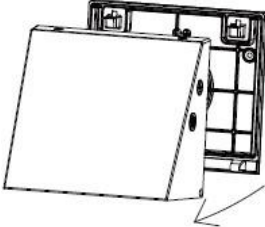
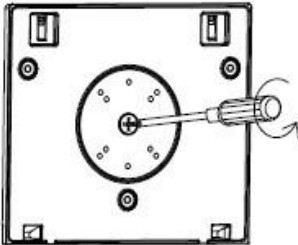
<p>1. Turn off the main power from the breaker panel.</p>	
<p>2. Loosen and remove the four screws from the top and sides of the fixture, holding the front cover to prevent it from falling.</p>	
<p>3. Open the light and remove the cover.</p> <p>If you do not need the photocell function, disconnect the male and female connector (see Photocell section for more information).</p>	
<p>4. Unscrew the 1/2" plug and attach an EVA foam pad (included).</p>	



5. Wall Mount Installation

- a. Drill through three mounting holes using an electric drill.
- b. Attach the EVA foam pad (included) to the base of the fixture. Attach the base of the fixture to the wall with screws (not provided).

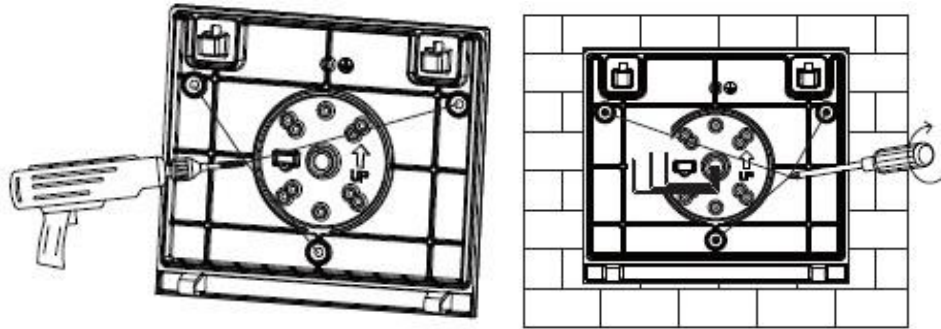

J-Box Installation

- a. Drill through the mounting holes using an electric drill.
- b. Attach the EVA foam pad (included) to the base of the fixture. Attach the fixture base to the J-box with screws (not provided).

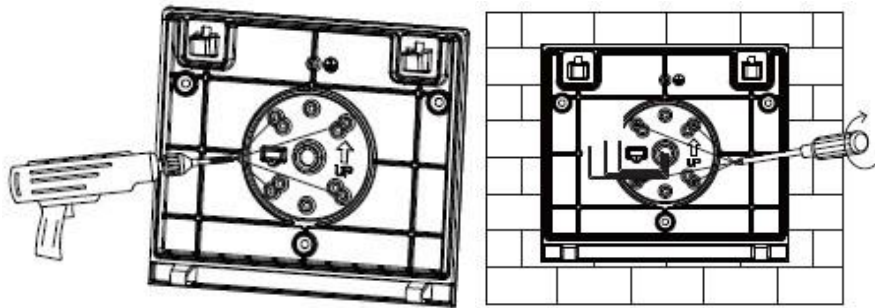

6. Fasten the screws and connect the L, N, and G wires to the power supply. Refer to the Wiring Diagram section.

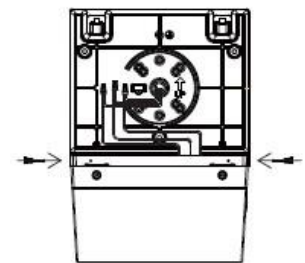

7. Mount the cover back onto the base of the fixture with the screws and seal the mounting surface with waterproof sealant (not provided).

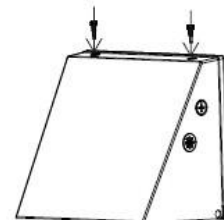



COLOR/WATTAGE SELECTABLE LED WALL PACK W/ PHOTOCELL

WARNING, CAUTION, SAFETY AND INSTALLATION INSTRUCTIONS

8. Select the desired wattage and color temperature using the DIP switches (see Adjustable Wattage & Color Temperature section for more information). Make sure the installation is complete before turning the power back on.

NOTE: The fixture must be turned OFF when selecting the CCT and wattage.

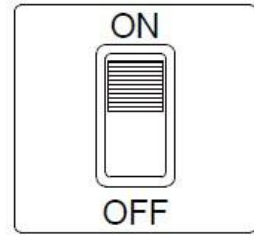

Wiring Diagram

- L/live Wire: Black/Brown
- N/Neutral Wire: White/Blue
- Ground Wire: Green/Yellow-green

Warning: During grounding, make sure the earth wire of the driver and light housing are connected together with the earth wires of the local power supply.

Note: This fixture includes a sensor receptacle. When a sensor is installed, it overrides the dimming circuit—do not connect to an external dimming device.

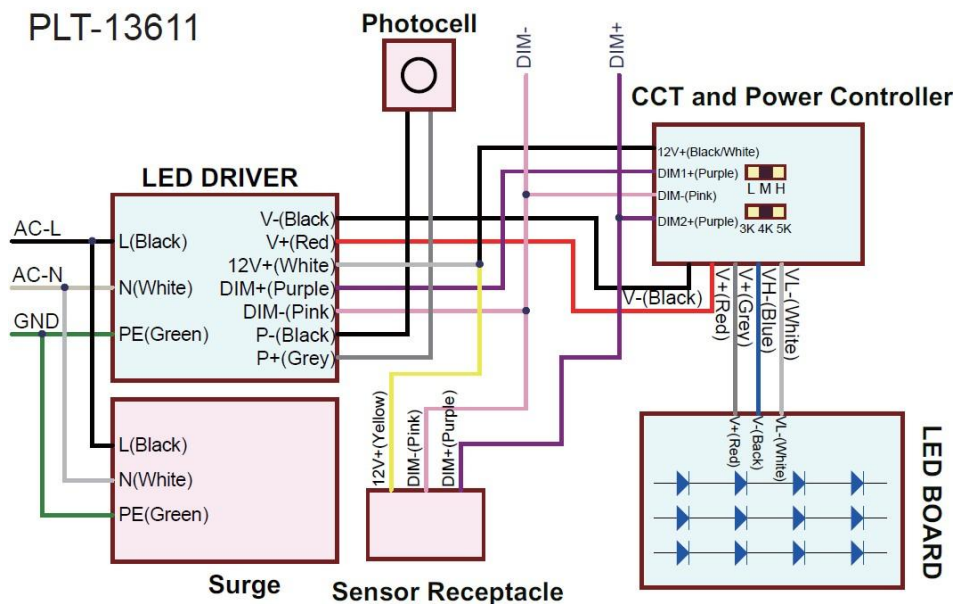
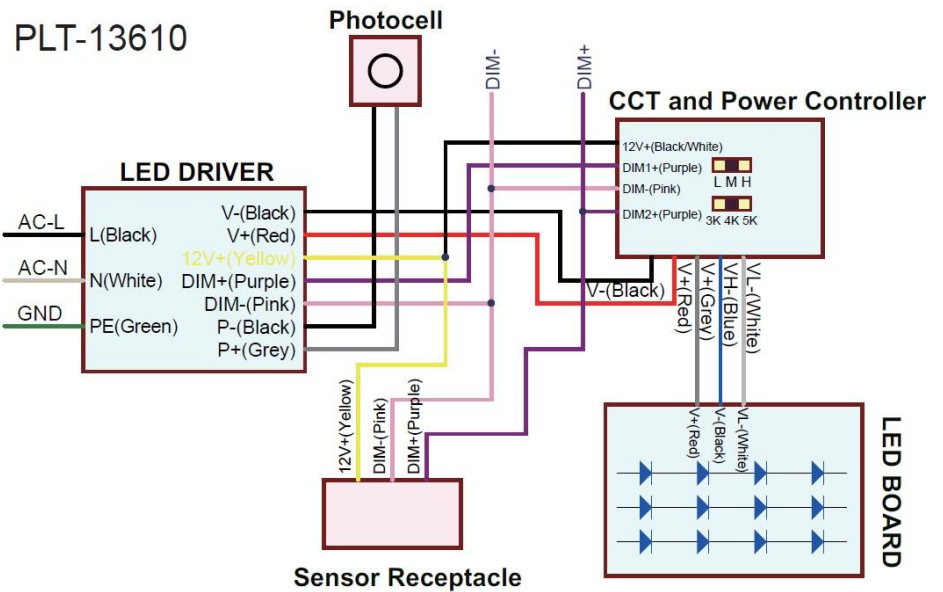



Drill Patterns

PLT-13610

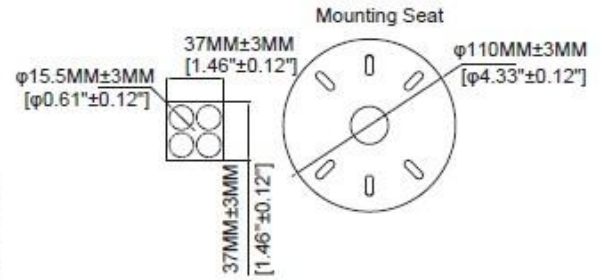
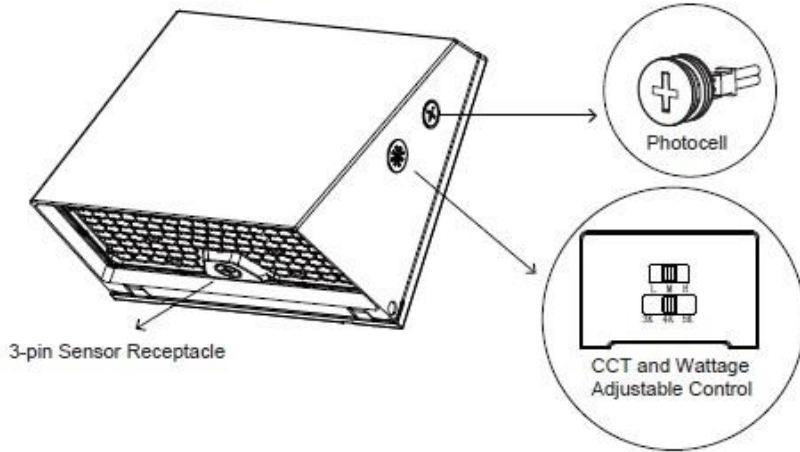

PLT-13611

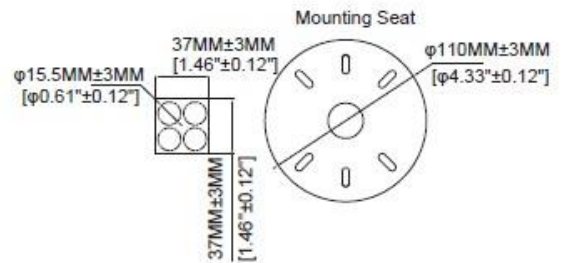
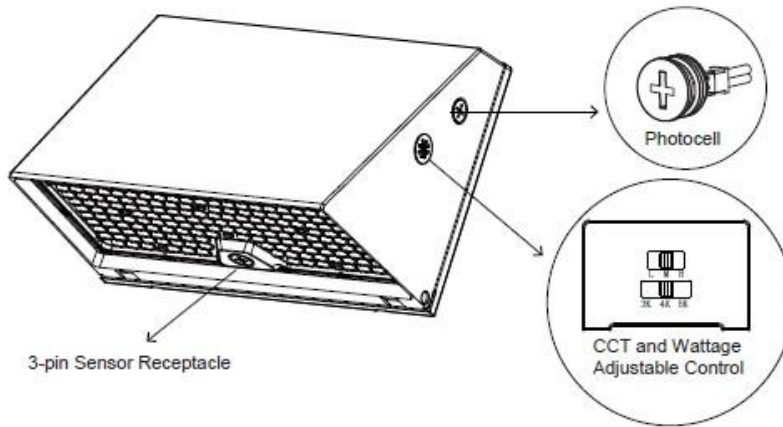

Photocell

Under the cover of the fixture, locate the male and female connectors adjacent to the 1/2" plug covering the photocell on the side of the fixture.

- Connecting the male and female connectors will activate the photocell function (Fig:1).
- Disconnecting the male and female connectors will deactivate the photocell function (Fig:2).

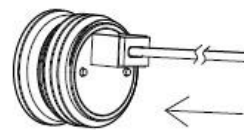

Fig:1

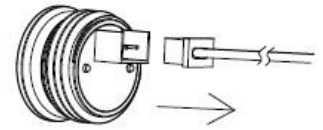

Fig:2



Adjustable Wattage & Color Temperature

CCT Instruction

Unscrew the 3/4" plug on the side of the fixture to reveal the two switches for color temperature and wattage.

- 3K = 3000K
- 4K = 4000K
- 5K = 5000K

NOTE: Turn OFF the power before adjusting the color temperature or wattage selection.

Wattage Instruction

The output power of the fixture will change to the corresponding wattage when selected.

Wattage Selections:

- PLT-13610: 30W, 40W, 60W
- PLT-13611: 80W, 100W, 120W

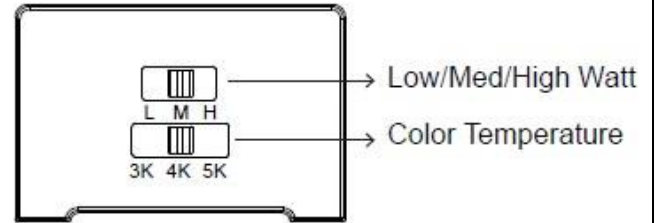

CCT and Wattage Adjustable Control

Default Settings

SKU	Default Settings
PLT-13610	60W, 5000K
PLT-13611	120W, 5000K

⚠ WARNING

- Before installing, servicing, or performing routine maintenance upon this equipment, follow these general precautions.
- To reduce the risk of death, personal injury, or property damage from fire, electric shock, falling parts, cuts/abrasions, and other hazards, read all warnings and instructions included with and on the fixture box and all fixture labels.
- Proper grounding is required to ensure safety.
- Power must be turned off at the breaker before installation or maintenance.
- This product must be installed in accordance with the applicable installation code by a person familiar with the construction and operation of the product and the hazards involved.
- Wear gloves and eye protection at all times while installing, servicing, or performing maintenance on the luminaire, and avoid direct eye exposure to the light source while it is on.
- To prevent wiring damage or abrasion, do not expose wiring to edges of sheet metal or other sharp objects.
- Do not install damaged product. Inspect luminaire for damage that may have occurred during transit. If damaged, contact the manufacturer immediately.
- These instructions do not purport to cover all details or variations in equipment nor to provide every possible contingency to meet in connection with installation, operation, or maintenance. Should further information be



desired or should particular problems arise which are not covered sufficiently for the purchaser's or owner's purposes, contact the manufacturer.

⚠ ADVERTENCIA

- Antes de instalar, reparar o realizar el mantenimiento de rutina de este equipo, siga estas precauciones generales.
- Para reducir el riesgo de muerte, lesiones personales o daños a la propiedad por fuego, descarga eléctrica, caída de piezas, cortes / abrasiones y otros peligros, lea todas las advertencias y instrucciones incluidas con y en la caja del dispositivo y todas las etiquetas del dispositivo.
- Se requiere una conexión a tierra adecuada para garantizar la seguridad.
- Se debe apagar la energía en el disyuntor antes de la instalación o el mantenimiento.
- Este producto debe ser instalado de acuerdo con el código de instalación aplicable por una persona familiarizada con la construcción y operación del producto y los peligros involucrados.
- Utilice guantes y protección para los ojos en todo momento durante la instalación, el servicio o el mantenimiento de la luminaria, y evite la exposición directa de los ojos a la fuente de luz mientras está encendida.
- Para evitar daños o abrasiones en el cableado, no exponga el cableado a bordes de láminas de metal u otros objetos afilados.
- No instale un producto dañado. Inspeccione la luminaria en busca de daños que puedan haber ocurrido durante el tránsito. Si está dañado, comuníquese con el fabricante de inmediato.
- Estas instrucciones no pretenden cubrir todos los detalles o variaciones en el equipo ni proporcionar todas las posibles contingencias a cumplir en relación con la instalación, operación o mantenimiento. Si desea obtener más información o si surgen problemas particulares que no están suficientemente cubiertos para los propósitos del comprador o propietario, comuníquese con el fabricante.