

PARA 2' x 2'

Parabolic Lens Troffer, Grid mount

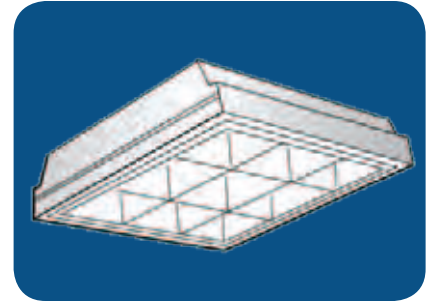

FEATURES & SPECIFICATIONS

INTENDED USE

Specification grade, parabolic lens troffer provides low glare, light cut-off, and visual comfort for all commercial and industrial buildings requiring general illumination with recessed configurations. Black perimeter (reveal) provides “floating” louver façade. Available in static and air return configurations.

SIZE W x L x H in inches (mm)

23.75W x 24.0L x 5.5Dp (600 x 610 x 140)

MATERIALS & FEATURES

Housing is die-formed and embossed code 22 gage steel. Finish is high reflectance baked white enamel, with black reveal support rails. Wiring knockouts are provided on back and end of housing. Ballast cover or reflector snaps into place; no tools required for ballast access. Louvers are formed from aluminum, are available in a variety of finishes and cell counts, and are held closed by two positive cam latches. Premium, full specular reflectors are available as an option to increase efficiency or modify lighting distribution.

- POST PAINTED POWDER COAT LUMINAIRE FINISH
- Aluminum louver - standard is low iridescent semi-specular (satin), also available in full specular (bright), and white finish.
- Louvers hinge from either side; field reversible.
- Access plate to simplify installation

LAMP

2, 3, or 4 lamp positions.

MOUNTING

Recessed inverted T-Bar ceilings. Grid mount.

LISTING

Fixture & Ballast: UL Listed

Ballast: Thermally protected, class P, HPF, Non PCB

TYPICAL OPTIONS AND ACCESSORIES

Emergency ballasts, whips, and frame kits. See options page at the end of the T02Grid section, or contact factory for more details.

ORDERING INFORMATION

Example: **PARA9C232UE120**

PARA	9C	2	32U	E120
Function	(blank) Static R Air Return			
Series	PARA Parabolic Louver, Grid Mount			
Lamp Count	2, 3, or 4 Lamps Not included			
Lamp Type [1]		20 24 in. T12 17 24 in. T8 14 23 in. T5 24 23 in. T5HO 32U T8 Ubend 6 in. leg 31U T8 Ubend 1.62 in. leg 40BX Biaxial (TT5) 2G11 4-Pin 40W		
Ballast & Voltage [1]				E120 Electronic, 120V E277 Electronic, 277V MV Electronic, Multivolt (120-277) H120 [4] Electronic, 120V, Hi-Lume H277 [4] Electronic, 277V, Hi-Lume H MV [4] Electronic, Multivolt, Hi-Lume L120 [4] Electronic, 120V, Lo-Lume L277 [4] Electronic, 277V, Lo-Lume LMV [4] Electronic, Multivolt, Lo-Lume G120 [5] Line Dimming, 120 Volt G277 [5] Line Dimming, 277 Volt GMV [5] Line or 0-10V dimming, Multivolt
Louver Cell Count & Material [2]	9C 9 cell (3x3 pattern) semi-specular, 3in nominal 12C 12 cell (3x4 pattern) semi-specular, 3in nominal 16C 16 cell (4x4 pattern) semi-specular, 3in nominal 9F 9 cell (3x3 pattern) Full specular, 3in nominal 16F 16 cell (4x4 pattern) Full specular, 3in nominal 9W 9 cell (3x3 pattern) White, 3in nominal 16W 16 cell (4x4 pattern) White, 3in nominal			
Reflector [3]			(blank) no reflector [3] M20 Mirrored reflector	
Options [1]				WP 6ft whip, 3/18ga WP10 6ft whip, 4/18ga EM Emergency ballast EM14 Emergency ballast, 1400Lumen

Notes

- [1] See end of T02Grid for many additional lamps, ballasts, finishes, and options.
 [2] Custom louvers available in any cell configuration. Contact factory for additional information.
 [3] Custom reflectors available to create any light distribution.
 [4] HiLume and LoLume ballasts available for T8 lamps only.
 [5] Line dimming ballasts available for T8 lamps only.
 [6] Magnetic ballasts available for T8 & T12 only.

EM14 ballast required for T5 & T5HO lamps

Catalog Number:

Notes:

PARA 2'x 2'

Parabolic Lens Troffer, Grid mount

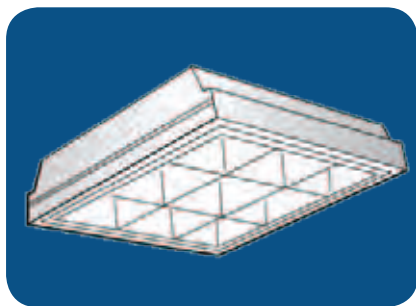

DIMENSIONS

All dimensions are inches. Specifications subject to change without notice.

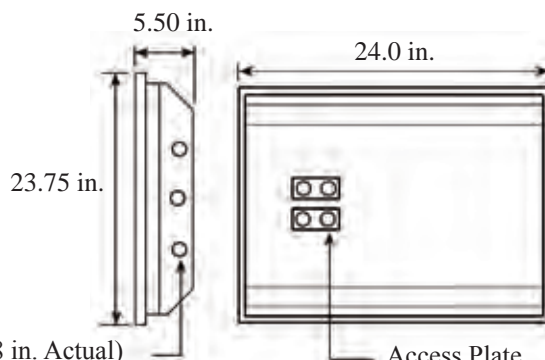

1/2' Nom. (0.88 in. Actual)
EKO In Both Ends and Back

Access Plate
On Center For 2 & 4 Lamp Models
Off Center For 3 Lamp Models

PHOTOMETRICS

Calculated using the zonal cavity method in accordance with IESNA LM41 procedure. Lamp configurations shown are typical. Photometric data on these and other configurations available upon request.

Floor	20%	20%	20%	20%	20%	20%	20%	20%	20%
Ceiling	80%	80%	80%	70%	70%	70%	50%	50%	50%
Wall	70%	50%	30%	70%	50%	30%	50%	30%	10%
RCR	Zonal cavity coefficients			PARA9C232U		Spacing ratio. Along 1.2 Across 1.4			
0	0.75	0.75	0.74	0.73	0.73	0.72	0.70	0.70	0.69
1	0.69	0.67	0.64	0.65	0.63	0.61	0.63	0.61	0.60
2	0.64	0.60	0.56	0.58	0.55	0.52	0.56	0.53	0.51
3	0.59	0.53	0.48	0.52	0.48	0.44	0.50	0.47	0.44
4	0.55	0.48	0.42	0.47	0.42	0.38	0.45	0.41	0.38
5	0.50	0.43	0.37	0.42	0.37	0.33	0.41	0.36	0.33
6	0.47	0.38	0.33	0.38	0.33	0.29	0.37	0.32	0.29
7	0.43	0.35	0.30	0.34	0.30	0.26	0.34	0.29	0.26
8	0.40	0.32	0.27	0.32	0.27	0.23	0.31	0.26	0.23
9	0.38	0.29	0.24	0.29	0.24	0.21	0.28	0.24	0.21
10	0.35	0.27	0.22	0.27	0.22	0.19	0.26	0.22	0.19

Floor	20%	20%	20%	20%	20%	20%	20%	20%	20%
Ceiling	80%	80%	80%	70%	70%	70%	50%	50%	50%
Wall	70%	50%	30%	70%	50%	30%	50%	30%	10%
RCR	Zonal cavity coefficients			PARA9C317		Spacing ratio. Along 1.2 Across 1.6			
0	0.79	0.78	0.78	0.77	0.76	0.76	0.73	0.73	0.73
1	0.73	0.7	0.68	0.71	0.69	0.67	0.66	0.64	0.63
2	0.68	0.63	0.59	0.66	0.62	0.58	0.59	0.56	0.54
3	0.62	0.56	0.51	0.61	0.55	0.51	0.53	0.5	0.46
4	0.58	0.5	0.45	0.56	0.5	0.45	0.48	0.44	0.41
5	0.53	0.45	0.4	0.52	0.45	0.4	0.43	0.39	0.36
6	0.49	0.41	0.35	0.48	0.4	0.35	0.39	0.35	0.31
7	0.46	0.37	0.32	0.45	0.37	0.32	0.36	0.31	0.28
8	0.43	0.34	0.29	0.42	0.34	0.29	0.33	0.28	0.25
9	0.4	0.31	0.26	0.39	0.31	0.26	0.3	0.26	0.23
10	0.38	0.29	0.24	0.37	0.29	0.24	0.28	0.24	0.21

Floor	20%	20%	20%	20%	20%	20%	20%	20%	20%
Ceiling	80%	80%	80%	70%	70%	70%	50%	50%	50%
Wall	70%	50%	30%	70%	50%	30%	50%	30%	10%
RCR	Zonal cavity coefficients			PARA16C417		Spacing ratio. Along 1.2 Across 1.4			
0	0.70	0.71	0.70	0.69	0.69	0.68	0.66	0.66	0.66
1	0.66	0.64	0.62	0.62	0.61	0.59	0.60	0.59	0.57
2	0.62	0.58	0.54	0.56	0.53	0.51	0.54	0.52	0.50
3	0.57	0.52	0.48	0.51	0.47	0.44	0.49	0.46	0.43
4	0.53	0.47	0.42	0.46	0.42	0.39	0.45	0.41	0.38
5	0.49	0.42	0.38	0.42	0.37	0.34	0.41	0.37	0.34
6	0.46	0.38	0.34	0.38	0.33	0.30	0.37	0.33	0.30
7	0.43	0.35	0.30	0.35	0.30	0.27	0.34	0.30	0.27
8	0.40	0.32	0.28	0.32	0.28	0.25	0.31	0.27	0.24
9	0.37	0.30	0.25	0.29	0.25	0.22	0.29	0.25	0.22
10	0.35	0.27	0.23	0.27	0.23	0.20	0.27	0.23	0.20

Floor	20%	20%	20%	20%	20%	20%	20%	20%	20%
Ceiling	80%	80%	80%	70%	70%	70%	50%	50%	50%
Wall	70%	50%	30%	70%	50%	30%	50%	30%	10%
RCR	Zonal cavity coefficients			PARA9C331UM20		Spacing ratio. Along 1.2 Across 1.3			
0	0.72	0.73	0.72	0.70	0.71	0.71	0.68	0.68	0.67
1	0.68	0.65	0.63	0.66	0.64	0.62	0.61	0.60	0.58
2	0.63	0.58	0.55	0.61	0.57	0.54	0.55	0.52	0.50
3	0.58	0.52	0.48	0.57	0.51	0.47	0.50	0.46	0.43
4	0.54	0.47	0.42	0.52	0.46	0.42	0.45	0.41	0.38
5	0.50	0.42	0.37	0.48	0.42	0.37	0.40	0.36	0.33
6	0.46	0.38	0.33	0.45	0.38	0.33	0.37	0.32	0.29
7	0.43	0.35	0.30	0.42	0.34	0.30	0.33	0.29	0.26
8	0.40	0.32	0.27	0.39	0.32	0.27	0.31	0.27	0.24
9	0.37	0.29	0.25	0.36	0.29	0.24	0.28	0.24	0.21
10	0.35	0.27	0.22	0.34	0.27	0.22	0.26	0.22	0.19

PARA 2' x 4'

Parabolic Lens Troffer, Grid Mount

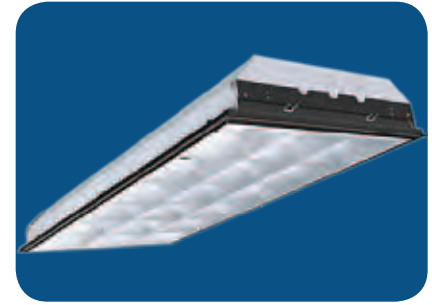

FEATURES & SPECIFICATIONS

INTENDED USE

Specification grade, parabolic lens troffer provides low glare, light cut-off, and visual comfort for all commercial and industrial buildings requiring general illumination with recessed configurations. Black perimeter (reveal) provides “floating” louver façade. Available in static and air return configurations.

SIZE W x L x H in inches (mm)

23.75W x 48.0L x 5.5Dp (300 x 1220 x 140)

MATERIALS & FEATURES

Housing is die-formed and embossed code 22 gage steel. Finish is high reflectance baked white enamel, with black reveal support rails. Wiring knockouts are provided on back and end of housing. Ballast cover or reflector snaps into place; no tools required for ballast access. Louvers are formed from aluminum, are available in a variety of finishes and cell counts, and are held closed by two positive cam latches. Premium, full specular reflectors are available as an option to increase efficiency or modify lighting distribution.

- POST PAINTED POWDER COAT LUMINAIRE FINISH
- Aluminum louver - standard is low iridescent semi-specular (satin), also available in full specular (bright), and white finish.
- Louvers hinge from either side; field reversible.
- Access plate to simplify installation

LAMP

2, 3, or 4 lamp positions

MOUNTING

Recessed inverted T-Bar ceilings. Grid mount.

LISTING

Fixture and Ballast: UL Listed.

Ballast: Thermally protected, class P, HPF, Non PCB.

TYPICAL OPTIONS AND ACCESSORIES

Emergency ballasts, whips, and frame kits. See options page at the end of the T02Grid section, or contact factory for more details.

ORDERING INFORMATION

Example: **PARA 18C 332 E120**

PARA	18C	3	32	E120
Series	Lamp Count			Ballast & Voltage [1]
PARA Parabolic Louver, Grid Mount	2, 3, or 4 Lamps Not included	40 32 28 54	48 in. T12 [7] 48 in. T8 46 in. T5 46 in. T5HO	E120 Electronic, 120V E277 Electronic, 277V MV Electronic, Multivolt (120-277) H120 [4] Electronic, 120V, Hi-Lume H277 [4] Electronic, 277V, Hi-Lume H MV [4] Electronic, Multivolt, Hi-Lume L120 [4] Electronic, 120V, Lo-Lume L277 [4] Electronic, 277V, Lo-Lume LMV [4] Electronic, Multivolt, Lo-Lume G120 [5] Line Dimming, 120 Volt G277 [5] Line Dimming, 277 Volt GMV [5] Line or 0-10V dimming, Multivolt
Function	Louver Cell Count & Material [2]			Reflector [3]
(blank) Static R Air Return	12C 12 cell (2x6 pattern) semi-specular, 3in nominal 16C 16 cell (2x8 pattern) semi-specular, 3in nominal 18C 18 cell (3x6 pattern) semi-specular, 3in nominal 32C 32 cell (4x8 pattern) semi-specular, 3in nominal 24C 24 cell (4x6 pattern) semi-specular, 3in nominal 18F 18 cell (3x6 pattern) Full specular, 3in nominal 32F 32 cell (4x8 pattern) Full specular, 3in nominal 18W 18 cell (3x6 pattern) White, 4in nominal 32W 32 cell (4x8 pattern) White, 4in nominal			(blank) no reflector [3] M20 Mirrored reflector
Notes	Options [1]			
[1] See end of T02Grid for many additional lamps, ballasts, finishes, and options. [2] Custom louvers available in any cell configuration. Contact factory for additional information. [3] Custom reflectors available to create any light distribution. [4] HiLume and LoLume ballasts available for T8 lamps only. [5] Dimming ballasts available for T8 & T5HO lamps only. [6] Magnetic ballasts available for T8 & T12 only. [7] Magnetic & electronic T12 ballasts drive a 34W energy saver lamp.	WP 6ft whip, 3/18ga WP10 6ft whip, 4/18ga EM Emergency ballast EM14 Emergency ballast, 1400Lumen EM14 ballast required for T5 & T5HO lamps			

Catalog Number:

Notes:

PARA 2' x 4'

Parabolic Lens Troffer, Grid Mount



DIMENSIONS

All dimensions are inches. Specifications subject to change without notice.

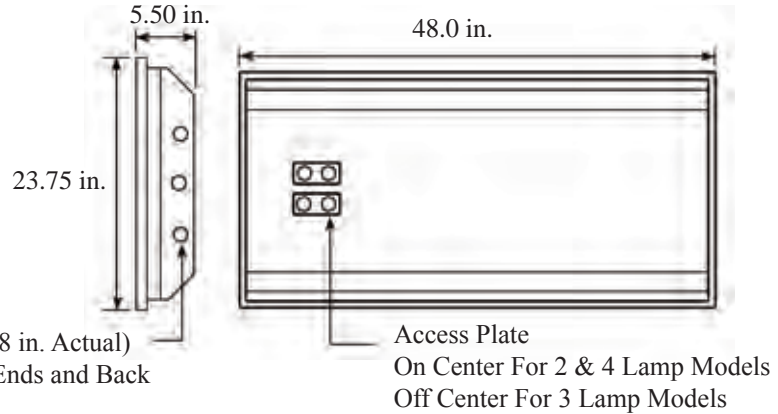

PHOTOMETRICS

Calculated using the zonal cavity method in accordance with IESNA LM41 procedure. Lamp configurations shown are typical. Photometric data on these and other configurations available upon request.

Floor	20%	20%	20%	20%	20%	20%	20%	20%	20%
Ceiling	80%	80%	80%	70%	70%	70%	50%	50%	50%
Wall	70%	50%	30%	70%	50%	30%	50%	30%	10%
RCR	Zonal cavity coefficients			PARA18C332		Spacing ratio. Along 1.2		Across 1.6	
0	0.84	0.84	0.83	0.82	0.81	0.81	0.78	0.78	0.78
1	0.78	0.75	0.73	0.74	0.71	0.69	0.71	0.69	0.67
2	0.73	0.68	0.63	0.66	0.63	0.59	0.64	0.61	0.58
3	0.67	0.61	0.55	0.59	0.55	0.51	0.58	0.54	0.50
4	0.62	0.55	0.49	0.54	0.49	0.45	0.52	0.48	0.44
5	0.58	0.49	0.43	0.48	0.43	0.39	0.47	0.42	0.39
6	0.53	0.44	0.39	0.44	0.38	0.34	0.43	0.38	0.34
7	0.50	0.40	0.35	0.40	0.35	0.31	0.39	0.34	0.31
8	0.46	0.37	0.32	0.37	0.31	0.28	0.36	0.31	0.28
9	0.43	0.34	0.29	0.34	0.28	0.25	0.33	0.28	0.25
10	0.41	0.31	0.26	0.31	0.26	0.23	0.30	0.26	0.23

Floor	20%	20%	20%	20%	20%	20%	20%	20%	20%
Ceiling	80%	80%	80%	70%	70%	70%	50%	50%	50%
Wall	70%	50%	30%	70%	50%	30%	50%	30%	10%
RCR	Zonal cavity coefficients			PARA32C432		Spacing ratio. Along 1.2		Across 1.3	
0	0.76	0.75	0.75	0.74	0.73	0.73	0.7	0.7	0.7
1	0.7	0.68	0.66	0.66	0.64	0.63	0.64	0.62	0.61
2	0.65	0.61	0.57	0.6	0.56	0.54	0.58	0.55	0.53
3	0.61	0.55	0.5	0.54	0.5	0.46	0.52	0.48	0.46
4	0.56	0.49	0.45	0.49	0.44	0.41	0.47	0.43	0.4
5	0.52	0.45	0.39	0.44	0.39	0.36	0.43	0.38	0.35
6	0.48	0.4	0.35	0.4	0.35	0.31	0.39	0.34	0.31
7	0.45	0.37	0.32	0.36	0.32	0.28	0.35	0.31	0.28
8	0.42	0.34	0.29	0.33	0.29	0.25	0.33	0.28	0.25
9	0.39	0.31	0.26	0.31	0.26	0.23	0.3	0.26	0.23
10	0.37	0.29	0.24	0.28	0.24	0.21	0.28	0.24	0.21

Floor	20%	20%	20%	20%	20%	20%	20%	20%	20%
Ceiling	80%	80%	80%	70%	70%	70%	50%	50%	50%
Wall	70%	50%	30%	70%	50%	30%	50%	30%	10%
RCR	Zonal cavity coefficients			PARA18C232M20		Spacing ratio. Along 1.2		Across 1.3	
0	0.91	0.9	0.9	0.89	0.88	0.88	0.84	0.84	0.84
1	0.85	0.81	0.78	0.83	0.8	0.77	0.77	0.74	0.73
2	0.78	0.73	0.68	0.76	0.71	0.67	0.69	0.65	0.62
3	0.72	0.65	0.59	0.7	0.64	0.59	0.62	0.57	0.54
4	0.67	0.58	0.52	0.65	0.57	0.52	0.56	0.51	0.47
5	0.62	0.52	0.46	0.6	0.52	0.46	0.5	0.45	0.41
6	0.57	0.47	0.41	0.56	0.47	0.41	0.45	0.4	0.36
7	0.53	0.43	0.37	0.52	0.43	0.37	0.41	0.36	0.32
8	0.5	0.4	0.34	0.49	0.39	0.33	0.38	0.33	0.29
9	0.46	0.36	0.3	0.45	0.36	0.3	0.35	0.3	0.26
10	0.43	0.34	0.28	0.43	0.33	0.28	0.32	0.27	0.24

Floor	20%	20%	20%	20%	20%	20%	20%	20%	20%
Ceiling	80%	80%	80%	70%	70%	70%	50%	50%	50%
Wall	70%	50%	30%	70%	50%	30%	50%	30%	10%
RCR	Zonal cavity coefficients			PARA18C332M20		Spacing ratio. Along 1.2		Across 1.3	
0	0.92	0.93	0.93	0.9	0.91	0.91	0.87	0.87	0.86
1	0.88	0.85	0.82	0.86	0.83	0.81	0.8	0.78	0.76
2	0.82	0.77	0.73	0.81	0.76	0.72	0.73	0.7	0.68
3	0.77	0.7	0.65	0.75	0.69	0.65	0.67	0.63	0.6
4	0.72	0.64	0.59	0.71	0.64	0.58	0.62	0.57	0.54
5	0.67	0.59	0.53	0.66	0.58	0.53	0.57	0.52	0.48
6	0.63	0.54	0.48	0.62	0.53	0.48	0.52	0.47	0.44
7	0.59	0.5	0.44	0.58	0.49	0.44	0.48	0.43	0.4
8	0.56	0.46	0.41	0.55	0.46	0.4	0.45	0.4	0.37
9	0.52	0.43	0.37	0.51	0.43	0.37	0.42	0.37	0.34
10	0.49	0.4	0.35	0.48	0.4	0.34	0.39	0.34	0.31